

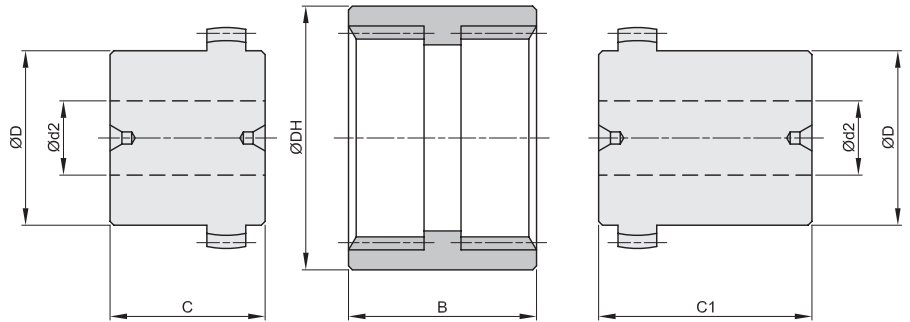

ACOPLAMIENTOS - "GFB"

GEAR COUPLINGS - "GFB"

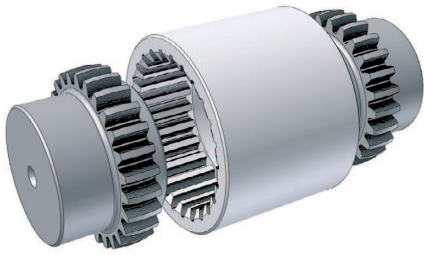

codice	foro	foro	manicotto			mozzo standard			mozzo lungo		
	Ød1	MAX	ØDH	B	peso	ØD	C	peso	ØD	C1	peso
	mm	mm	mm	mm	Kg	mm	mm	Kg	mm	mm	Kg
GFB-14	-	15	40	37	0,02	24	23	0,09	24	40	0,15
GFB-19	-	20	48	37	0,03	30	25	0,15	30	40	0,23
GFB-24	-	24	52	41	0,04	36	26	0,22	36	50	0,40
GFB-28	-	28	66	46	0,07	44	40	0,50	44	55	0,69
GFB-32	-	32	76	48	0,09	50	40	0,67	50	55	0,90
GFB-38	-	38	83	48	0,11	58	40	0,80	58	60	1,30
GFB-42	-	42	92	50	0,14	65	42	1,17	65	60	1,60
GFB-48	-	48	95	50	0,16	67	50	1,43	67	60	1,70
GFB-65	23	65	132	68	0,37	96	55	3,20	96	70	4,05

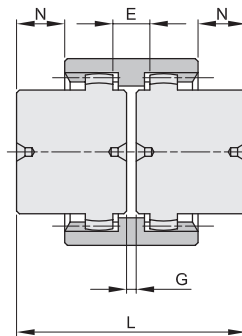

GFB-SS

2 mozzi standard

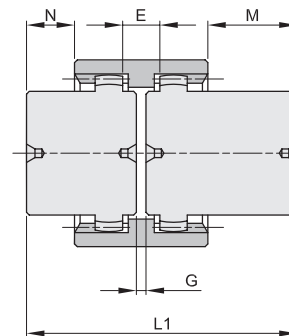

GFB-SL

1 mozzo standard
1 mozzo lungo

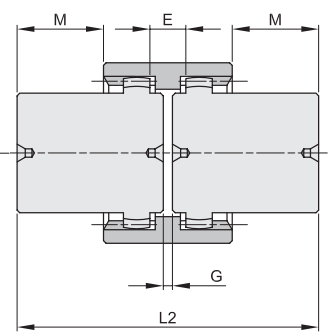

GFB-LL

2 mozzi lunghi

codice					GFB-SS		GFB-SL		GFB-LL	
	G	E	M	N	L	peso	L1	peso	L2	peso
	mm	mm	mm	mm	mm	Kg	mm	Kg	mm	Kg
GFB-14	4	15	40	6,5	50	0,20	67	0,26	84	0,32
GFB-19	4	20	48	8,5	54	0,33	69	0,41	84	0,49
GFB-24	4	24	52	7,5	56	0,48	80	0,66	104	0,84
GFB-28	4	28	66	19	84	1,07	99	1,26	114	1,45
GFB-32	4	32	76	18	84	1,43	99	1,66	114	1,89
GFB-38	4	38	83	18	84	1,71	104	2,21	124	2,71
GFB-42	4	42	92	19	88	2,48	106	2,91	124	3,34
GFB-48	4	48	95	27	104	3,02	114	3,29	124	3,56
GFB-65	4	65	132	23	114	6,77	129	7,62	144	8,47



ACOPLAMIENTOS - "GFB"

GEAR COUPLINGS - "GFB"

Descrizione e caratteristiche

- Costituiti da due mozzi in acciaio ed un manicotto in resina poliammide dentato internamente;
- Permettono un'ottima compensazione negli spostamenti assiali, radiali ed angolari nel collegamento degli alberi;
- I giunti con dentatura bombata e l'accoppiamento acciaio-resina non richiedono alcuna manutenzione;
- Di facile montaggio sia in orizzontale che in verticale;
- Temperatura di impiego da -25° a +100°

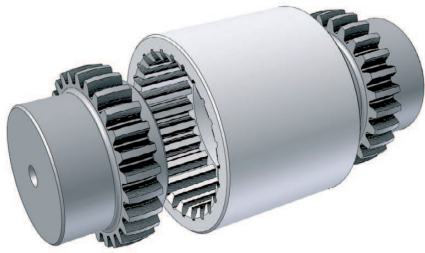

Characteristics

- Consist in two curved toothed hubs made in steel and one internally toothed sleeve made in polyamide;
- Able to compensate for axial, radial and angular misalignments of the connected shafts;
- Steel and polyamide combination makes maintenance-free;
- Easy to be mounted both in vertical and horizontal planes;
- Suitable for temperatures from -25° to +100°

codice	coppia		fattore di potenza		potenza trasmissibile (KW giri/1')										J*
	Nm		$\frac{P}{n}$		750		1000		1500		3000		giri/1'	Kg cm ²	
	norm.	max	norm.	max	norm.	max	norm.	max	norm.	max	norm.	max			
GFB-14	10	20	0,0010	0,0021	0,79	1,57	1,05	2,09	1,57	3,14	3,14	6,28	14000	0,3	
GFB-19	16	32	0,0017	0,0034	1,26	2,51	1,68	3,35	2,51	5,03	5,03	10,05	11800	0,5	
GFB-24	20	40	0,0021	0,0042	1,57	3,14	2,09	4,19	3,14	6,28	6,28	12,57	10600	1,0	
GFB-28	45	90	0,0047	0,0094	3,53	7,07	4,71	9,42	7,07	14,14	14,14	28,27	8500	3,1	
GFB-32	60	120	0,0063	0,0126	4,71	9,42	6,28	12,57	9,42	18,85	18,85	37,70	7500	5,5	
GFB-38	80	160	0,0084	0,0168	6,28	12,57	8,38	16,75	12,57	25,13	25,13	50,26	6700	8,7	
GFB-42	100	200	0,0105	0,0209	7,85	15,71	10,47	20,94	15,71	31,41	31,41	62,83	6000	14,3	
GFB-48	140	280	0,0147	0,0293	10,99	21,99	14,66	29,32	21,99	43,98	43,98	87,96	5600	18,4	
GFB-65	380	760	0,0398	0,0796	29,84	59,69	39,79	79,58	59,69	119,37	119,37	238,74	4000	109,0	

* Momento d'inerzia riferito al giunto
con mozzo standard con foro MAX (ød2)

codice	disassamento massimo per ogni mozzo		spostamento assiale (mm)
	ka (Δ)	kr(mm)	
GFB-14	± 2°	± 0,3	± 1
GFB-19	± 2°	± 0,4	± 1
GFB-24	± 2°	± 0,4	± 1
GFB-28	± 2°	± 0,5	± 1
GFB-32	± 2°	± 0,5	± 1
GFB-38	± 2°	± 0,5	± 1
GFB-42	± 2°	± 0,5	± 1
GFB-48	± 2°	± 0,5	± 1
GFB-65	± 2°	± 0,6	± 1

Norme di montaggio

- 1) Fissare i due mozzi agli alberi da accoppiare. La facciata interna del mozzo deve risultare a filo dell'estremità del rispettivo albero;
- 2) Infilare il manicotto sui due mozzi e regolare la distanza dei giunti come da quota "G";
- 3) Fissare in questa posizione i due alberi da accoppiare;
- 4) Accertarsi che il manicotto sia libero di spostarsi assialmente.

Mounting instructions

- 1) Fix the two hubs to the shafts. The inner sides of the hubs must be aligned with the shaft ends;
- 2) Insert the sleeve on the two hubs and adjust the distance of elements as per size "G";
- 3) Fix to this position the two elements to be coupled;
- 4) The sleeve must be free to move axially.

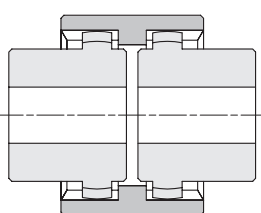

allineati

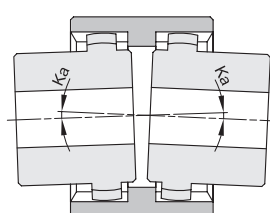

disassamento angolare

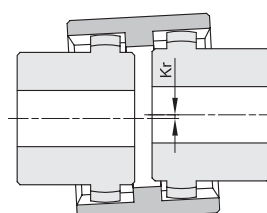

disassamento radiale

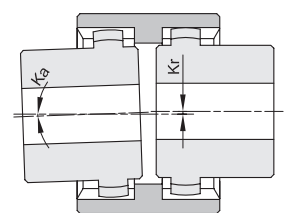

disassamento radiale/angolare